

Manhole Box 2.4m x 2.0m

Page 1 : Introduction, Design, Trench Reinstatement

Page 2 : Component Identification & Dimensions, Dimensions and Weights of Aluminium Manhole Box, Connection Details

Page 3 : Off Loading and Site Handling of Aluminium Manhole Box, Stacking, Handling and Transportation

Page 4 : Site Assembly of Manhole Box

Page 5 : Installation of Aluminium Manhole Box

Page 6 : Before Entering the Manhole Excavation, Entering the Supported Excavation

Page 7 : Extraction of Manhole Boxes, Precautions During Use and Maintenance, General

1. Introduction

This booklet is intended to provide basic information for users of the LITE guard Aluminium Manhole Box 2.4m x 2.0m and to draw the client's attention to the practical aspects of Manhole Box assembly and installation which need to be considered in compiling method statements. In particular, the client's attention is drawn to the size and weights of the Aluminium Manhole Box components and the need for planning the lifting operations involved. The Aluminium Manhole Box panels have lifting points for safe slinging when the box is assembled. Lifting operations during box assembly require slinging techniques as detailed in sections 9 and 10.

It is assumed that clients are familiar with general safe practices applicable to this type of work. The Manhole Box is a trench support system for support of trenches up to 2.3m deep and is not intended for other purposes. Aluminium Manhole Boxes should NOT be used in seawater applications without prior consultation with LITE guard.

2. Design

Methods of estimating lateral earth pressure vary. Typical working pressures that the Aluminium Manhole Box can sustain are as shown below and should satisfy most situations. Contact LITE guard if further assistance is required. Users are advised to check that their excavation arrangement will not impose greater working pressures than these.

Conditions which are likely to increase the lateral earth pressure include:

- Close proximity of structures.
- Excavated or construction materials adjacent to the trench.
- Close proximity of site roads.
- Close proximity of railways.

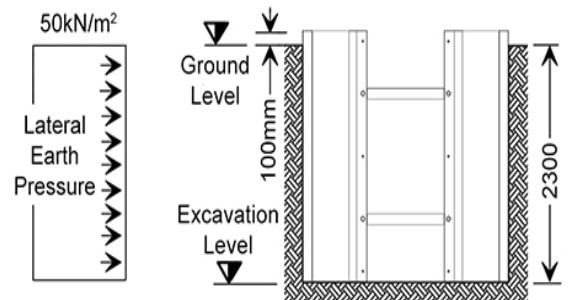

3. Trench Reinstatement

Users should note that some settlement of the reinstated ground and ground adjacent to the trench is likely to occur after backfilling.

Manhole Box 2.4m x 2.0m

4. Component Identification and Dimensions

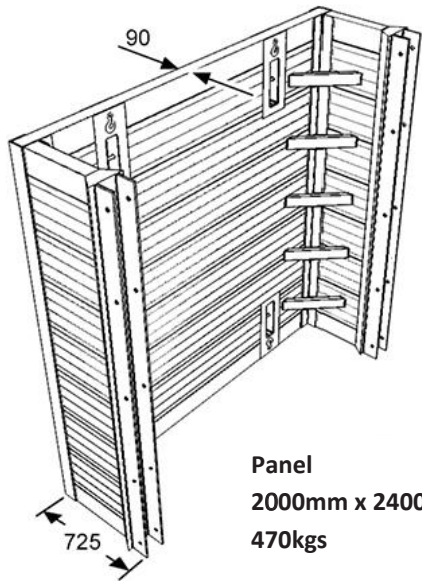

Panel
2000mm x 2400mm x 90mm
470kgs



Chain Sling

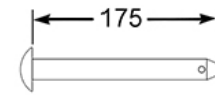

Pin for Fixed Strut

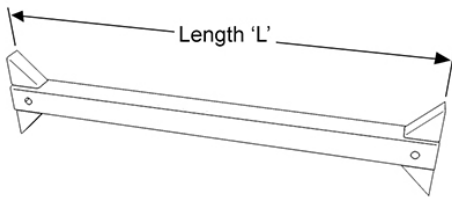

Struts come in various sizes
600mm, 800mm, 1000mm

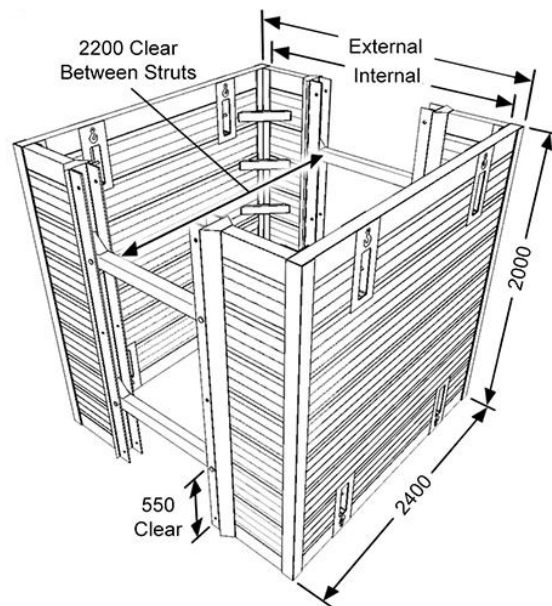

5. Dimensions and weights of Aluminium Manhole Box

Panel Type	Panel Length mm	Panel Height mm	Safe Working Load (kN/m ²)	Panel Thickness mm	Under Strut Clearance	Unit weight Incl. 1000mm Struts
Unit	2000	2000	70	90	1150	1000
Unit	2400	2000	50	90	1150	1155

6. Connection Details

The fixed strut is connected to the Manhole Panel using the 20 dia pin and secured with 'R' Clip. (See section 9 for Box Assembly details)

Manhole Box 2.4m x 2.0m

7. Off Loading and Site Handling of Aluminium Manhole Boxes

7.1 Manpower The Health and Safety Legislation requires that personnel deployed are suitably trained, experienced and supervised by a competent person. The main activities associated with Aluminium Trench Shield installation are :-

- Unloading the delivery vehicle.
- Pinning the components together.
- Lifting the assembled shield into and out of the trench.

7.2 Plant for Lifting

A suitable appliance is required for off-loading and assembly. The machine lifting capacity and clearance under the lifting point should be checked against the sizes and weights of the box components and against the assembly / dismantling stages.

WARNING: If an excavator is being used for lifting operations Lifting Chains should be used.

7.3 Lifting Chains

Lifting Chains of suitable length and capacity complete with current certification. Typically for Aluminium Trench Shield a set of 4 leg 7mm chains with 4m leg length complete with safety hooks and shortening clutches.

7.4 Edge Protection, Access and Hard Standing Areas

These include:-

7.4.1 Suitable area to off-load the truck and assemble the Aluminium Trench Shield.

7.4.2 Suitable hard standing for the machine to operate to lift the shield into the trench.

7.4.3 Suitable access equipment (ladder or staging) for connection / removal of lifting chains.

7.4.4 Edge protection, ladders and possibly other provisions to provide safe access into and out of the trench.

8. Stacking, Handling and Transportation

8.1 In Dismantled Form and in Transit

Manhole panels should be stacked as shown with suitable timber dunnage. (Max 4 panels per stack).

Struts and pins etc should be stored in skips / bins.

During transportation stacks should be securely restrained to the vehicle bed.

8.2 Site Storage

Important due to their light weight, boxes should be stored on their side when not in use to prevent them from being blown over.

Lie base boxes on their side,

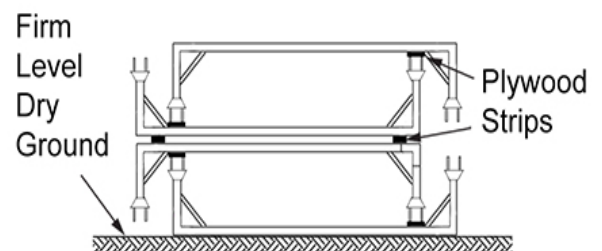
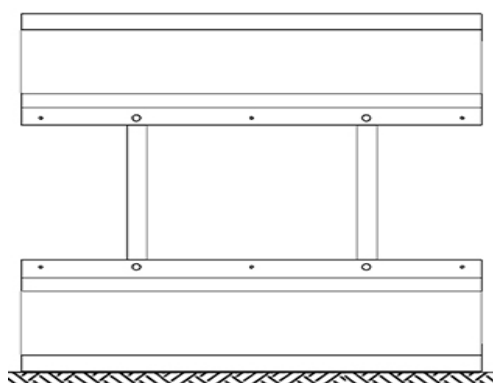

Manhole Box 2.4m x 2.0m

9. Site Assembly of Aluminium Manhole Boxes (dismantling is reverse procedure)

NOTE: It is important that the struts are fully retracted at all stages to maintain full range of strut adjustment.

9.1

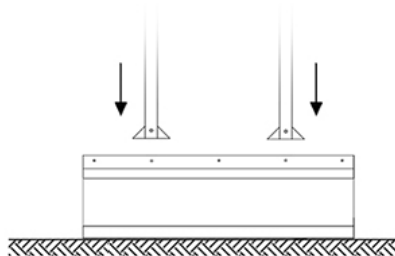

Lie first base panel flat on the ground with the wings pointing upwards. Pin fixed struts into position using the pins and 'R' clips. Each strut should be lifted in turn using a choke hitch around one of the strut ends.

Attach chain legs to lifting points

9.2

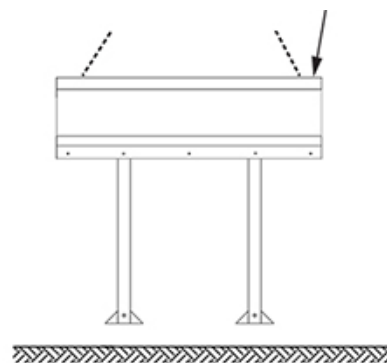
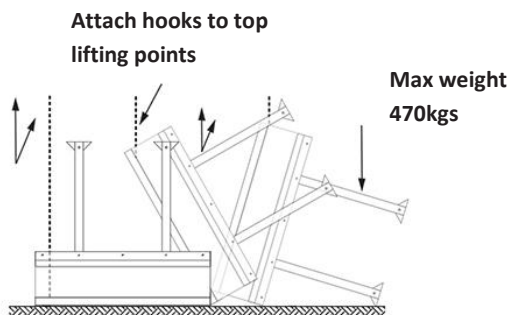

Carefully turn this panel over using 2 legs of the 4 leg sling, Re-sling this panel with the struts hanging downwards (Use all 4 legs of the lifting chain). Hold the panel on the lifting chains.

9.3

Complete the assembly of the Manhole box on its side by pinning the struts to the lower panel using the pins and securing with 'R' clips. Do not release the weight of the top panel until all of the pins and clips are in place.

Remove the 4 leg sling

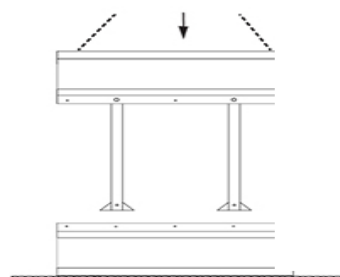

- A crane may be required to assemble boxes
- Suitable access may be required to move chains

9.4

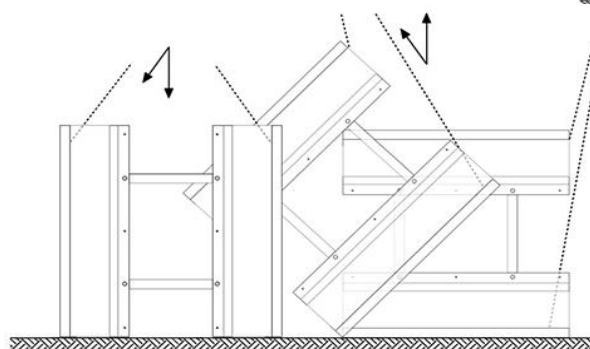

Max weight 1000kgs

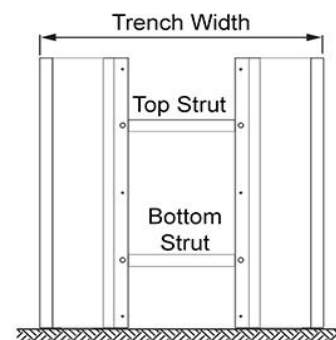

Attach 2 chains of the 4 leg sling to the UPPER lifting points of uppermost panel and 2 chains to the UPPER lifting points of the lowermost panel. Stand the box upright with great care to avoid damaging the struts. It is important to ensure the weights and radius are well within the lifting capacity of the machine to allow for impact and lurching effects as the box is turned upright, the completed base box can now be lifted on 4 chain legs. See section 8 for guidance on safe storage.

Manhole Box 2.4m x 2.0m

10. Installation of Aluminium Manhole Box

10.1

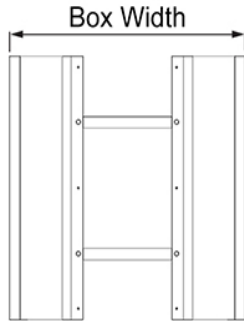

After following the assembly procedure, shown in section 9, check all pins and 'R' clips are securely in place.

10.2

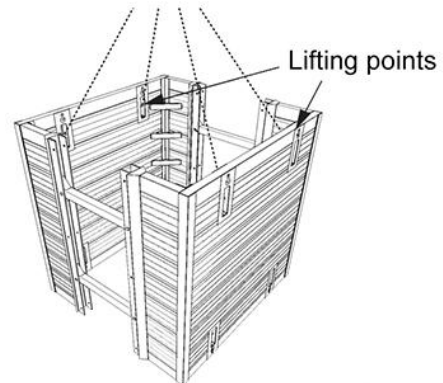

Lift the box using the 4 leg chain sling attached to the lifting points at the top of each Manhole box panel. Max weight 1000kgs approx.

10.3

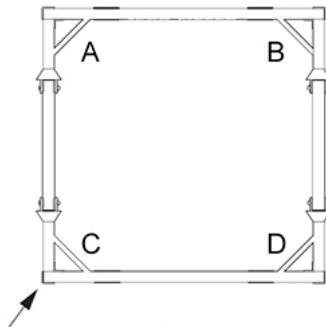

Push on corner

Dig the Manhole to the correct width and as close to full depth as reasonably practicable. Using the 4 leg chain sling place the box in the excavation. If full depth is not achieved prior to placement, the manhole box can be installed to correct depth by digging between the box panels and CAREFULLY pushing down on the ends of the panels. Always dig below the panels before pushing down. Push only on the corners of each panel and never in the middle.

When pushing the box panels down, always push down on each panel in the sequence shown and never diagonally across corners. i.e push A then B followed by C then D, and not A then C or B then D.

10.4

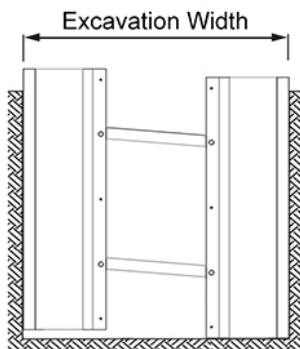

Rotation about pinned strut end is limited. Great care must be taken not to push too far on the panel corners during the 'dig and push' operation (10.3) so as not to cause damage to struts or panels.

10.5

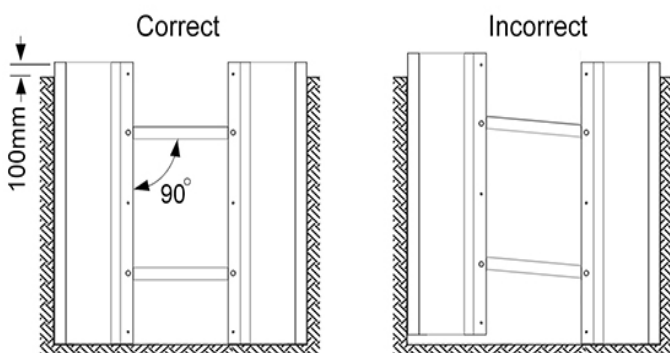

When the required excavation level is reached and the box sunk to full depth, ensure the struts are horizontal and at right angles to the panels before entering the excavation.

DO NOT use any supported part of the excavation for access. Leave the top of the box 100mm min. above the surrounding ground level.

Manhole Box 2.4m x 2.0m

11. Before Entering the Manhole Excavation

11.1 General

✓ Correct

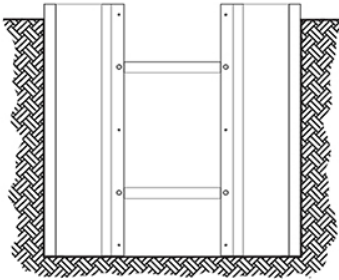

✗ Incorrect

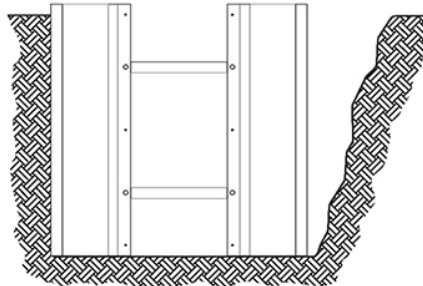

Ensure that there are no voids between the box panel and the trench sides as this may cause the box to move sideways.

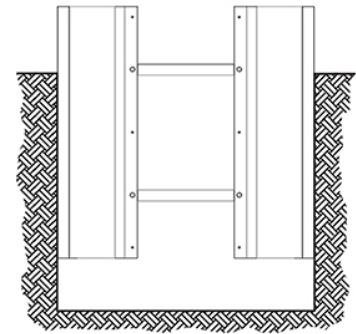

DO NOT leave the base of the box 'flying' above the excavation level.

11.2 End Closures

When stopping off the end of the trench, steel walers should be used to support the sheets supported off the projections at the end of the panel wings. Never use the struts as supports for the trench sheets. LITE guard can supply End Panels to close off the end of the trench.

Walings and Trench Sheets,
or alternatively, End Panels

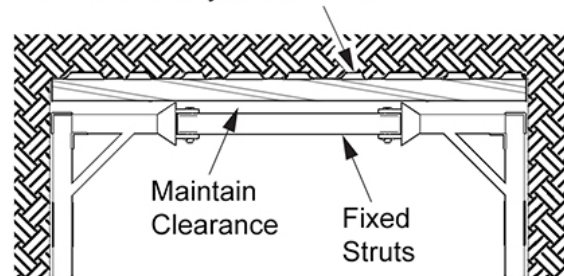

12. Entering the Supported Excavation

12.1 Use a ladder to enter the working space between the struts of the Manhole Box.

DO NOT climb up or down the struts.

12.2 **DO NOT** use panel corner braces as a means of access.

12.3 **DO NOT** use any unsupported part of the trench for access.

12.4 **DO NOT** move the box when personnel are inside it.

12.5 Wear a safety helmet to minimise risk of injury.

12.6 Ensure that the excavator operator is aware of your intentions.

Manhole Box 2.4m x 2.0m

13. Extraction of Manhole Boxes

Due to the consolidation of the ground against the panels, it is usually more difficult to extract Manhole boxes than to insert them. Methods for extracting are as follows, remembering that all lifting must be done at the points provided.

NOTE: No personnel should be inside the Manhole Box whilst extraction is in progress.

After initial backfilling and compaction, lift the box from the manhole using the 4 leg chain attached to all upper lifting points of the panels. Continue backfilling as removal of the box proceeds.

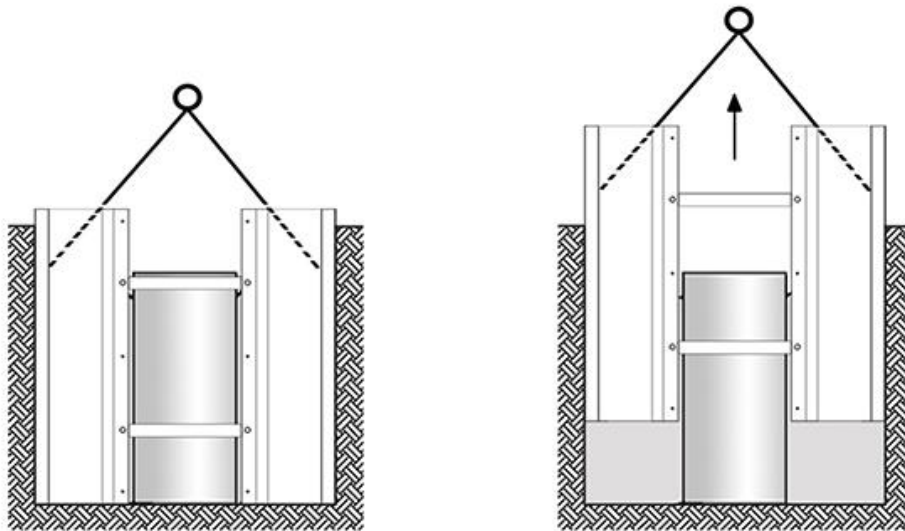

14. Precautions During Use and Maintenance

14.1 Regularly check all pins are in place and 'R' clips are fitted.

14.2 Avoid laterally loading the struts – either by hanging or propping from them or by accidentally striking them with site plant. Damaged struts should not be used.

15. General

Since our policy is one of continual improvement, components may vary in detail from the descriptions given in the publication.